

ANALOG Switch

L74VHC1GT66

The L74VHC1GT66 is an advanced high speed CMOS bilateral analog switch fabricated with silicon gate CMOS technology. It achieves high speed propagation delays and low ON resistances while maintaining low power dissipation. This bilateral switch controls analog and digital voltages that may vary across the full power-supply range (from V_{CC} to GND).

The L74VHC1GT66 is compatible in function to a single gate of the very High Speed CMOS MC74VHCT4066. The device has been designed so that the ON resistances (R_{ON}) are much lower and more linear over input voltage.

The ON/OFF Control input is compatible with TTL-type input thresholds allowing the device to be used as a logic-level translator from 3.0 V CMOS logic to 5.0 V CMOS logic or from 1.8 V CMOS logic to 3.0 V CMOS logic while operating at the high-voltage power supply. The input protection circuitry on this device allows overvoltage tolerance on the input, which provides protection when voltages of up to 7 V are applied, regardless of the supply voltage. This allows the L74VHC1GT66 to be used to interface 5 V circuits to 3 V circuits.

- High Speed: $t_{PD} = 20 \text{ ns}$ (Typ) at $V_{CC} = 5 \text{ V}$
- Low Power Dissipation: $I_{CC} = 2 \mu\text{A}$ (Max) at $T_A = 25^\circ\text{C}$
- Diode Protection Provided on Inputs and Outputs
- Improved Linearity and Lower ON Resistance over Input Voltage
- On/Off Control Input Has OVT

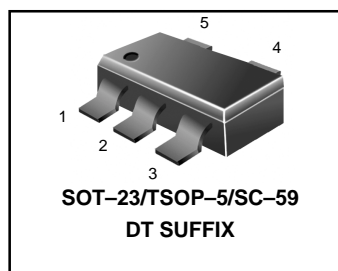
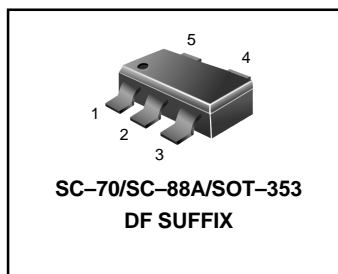

MARKING DIAGRAMS

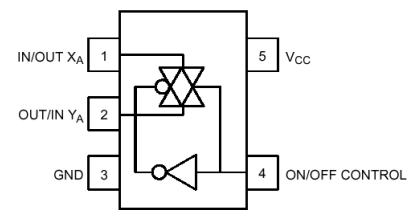
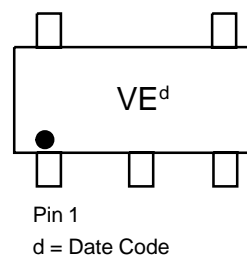
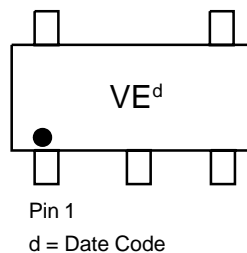

Figure 1. Pinout (Top View)

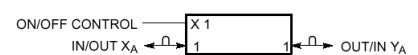

Figure 2. Logic Symbol

| PIN ASSIGNMENT | |
|----------------|-----------------------|
| 1 | IN/OUT X _A |
| 2 | OUT/IN Y _A |
| 3 | GND |
| 4 | ON/OFF CONTROL |
| 5 | V _{CC} |

| FUNCTION TABLE | |
|------------------------|---------------------|
| On / Off Control Input | State Analog Switch |
| L | Off |
| H | On |

ORDERING INFORMATION

See detailed ordering and shipping information in the package dimensions section on page 7 of this data sheet.

L74VHC1GT66

MAXIMUM RATINGS

| Symbol | Parameter | Value | Unit | |
|-----------------------|--|-------------------------------|-------|----|
| V _{CC} | DC Supply Voltage | - 0.5 to + 7.0 | V | |
| V _{IN} | DC Input Voltage | - 0.5 to +7.0 | V | |
| V _{IS} | Analog Output Voltage | -0.5 to +7.0 | V | |
| I _{IK} | Input Diode Current | -20 | mA | |
| I _{CC} | DC Supply Current, V _{CC} and GND | +25 | mA | |
| P _D | Power dissipation in still air | SC-88A (Note 2.) | 200 | mW |
| | | TSOP5 (Note 2.) | 450 | |
| T _L | Lead Temperature, 1 mm from Case for 10 s | 260 | °C | |
| T _{stg} | Storage temperature | -65 to +150 | °C | |
| V _{ESD} | ESD Withstand Voltage | Human Body Model (Note 3) | >2000 | V |
| | | Machine Model (Note 4) | > 200 | |
| | | Charged Device Model (Note 5) | N/A | |
| I _{LATCH-UP} | Latch-Up Performance Above V _{CC} and Below GND at 125°C (Note 6) | ± 500 | mA | |

1. Maximum Ratings are those values beyond which damage to the device may occur. Exposure to these conditions or conditions beyond those indicated may adversely affect device reliability. Functional operation under absolute-maximum-rated conditions is not implied. Functional operation should be restricted to the Recommended Operating Conditions.
2. Derating – SC-88A Package: -3 mW/°C from 65°C to 125°C
 – TSOP5 Package: -6 mW/°C from 65°C to 125°C
3. Tested to EIA/JESD22-A114-A
4. Tested to EIA/JESD22-A115-A
5. Tested to JESD22-C101-A
6. Tested to EIA/JESD78

RECOMMENDED OPERATING CONDITIONS

| Symbol | Parameter | Min | Max | Unit | |
|---------------------------------|-----------------------------|-------------------------------|-----------------|------|------|
| V _{CC} | DC Supply Voltage | 2.0 | 5.5 | V | |
| V _{IN} | DC Input Voltage | GND | 5.5 | V | |
| V _{IS} | Analog Input Voltage | GND | V _{CC} | V | |
| T _A | Operating Temperature Range | - 55 | + 125 | °C | |
| t _r , t _f | Input Rise and Fall Time | V _{CC} = 3.3 ± 0.3 V | 0 | 100 | ns/V |
| | | V _{CC} = 5.0 ± 0.5 V | 0 | 20 | |

The θ_{JA} of the package is equal to 1/Derating. Higher junction temperatures may affect the expected lifetime of the device per the table and figure below.

DEVICE JUNCTION TEMPERATURE VERSUS TIME TO 0.1% BOND FAILURES

| Junction Temperature °C | Time, Hours | Time, Years |
|-------------------------|-------------|-------------|
| 80 | 1,032,200 | 117.8 |
| 90 | 419,300 | 47.9 |
| 100 | 178,700 | 20.4 |
| 110 | 79,600 | 9.4 |
| 120 | 37,000 | 4.2 |
| 130 | 17,800 | 2.0 |
| 140 | 8,900 | 1.0 |

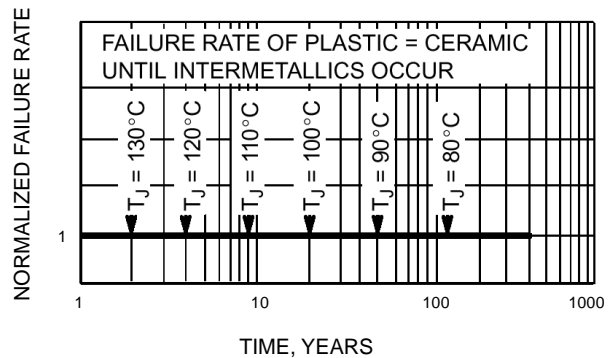

Figure 3. Failure Rate vs. Time Junction Temperature

L74VHC1GT66
DC ELECTRICAL CHARACTERISTICS

| Symbol | Parameter | Test Conditions | V _{CC} (V) | T _A = 25°C | | T _A ≤ 85°C | | T _A ≤ 125°C | | Unit |
|--------------------|--|---|------------------------|-----------------------|------|-----------------------|------|------------------------|------|------|
| | | | | Min | Max | Min | Max | Min | Max | |
| V _{IH} | Minimum High-Level Input Voltage On/Off Control Input | R _{ON} =Per Spec | 3.0 | 1.2 | | 1.2 | | 1.2 | | V |
| | | | 4.5 | 2.0 | | 2.0 | | 2.0 | | |
| | | | 5.5 | 2.0 | | 2.0 | | 2.0 | | |
| V _{IL} | Maximum Low-Level Input Voltage | R _{ON} =Per Spec | 3.0 | | 0.53 | | 0.53 | | 0.53 | V |
| | | | 4.5 | | 0.8 | | 0.8 | | 0.8 | |
| | | | 5.5 | | 0.8 | | 0.8 | | 0.8 | |
| I _{IN} | Maximum Input Leakage Current On/Off Control Input | V _{IN} =x V _{CC} or GND | 0 to 5.5 | | ±0.1 | | ±1.0 | | ±1.0 | μA |
| I _{CC} | Maximum Quiescent Supply Current | V _{IN} = V _{CC} or GND | 5.5 | | 2.0 | | 20 | | 40 | μA |
| I _{CC(T)} | Quiescent Supply Current | On/Off Control at 3.4 V | 5.5 | | 1.35 | | 1.50 | | 1.65 | mA |
| R _{ON} | Maximum "ON" Resistance | V _{IN} = V _{IH} V _{IS} = V _{CC} or GND I _{IS} ≤ 10 mA (Figure 4.) | 3.0 | | 60 | | 70 | | 100 | Ω |
| | | | 4.5 | | 45 | | 50 | | 60 | |
| | | | 5.5 | | 40 | | 45 | | 55 | |
| I _{OFF} | Maximum Off-Channel Leakage Current | V _{IN} = V _{IL} V _{IS} = V _{CC} or GND Switch Off (Figure 5.) | 5.5 | | 0.1 | | 0.5 | | 1.0 | mA |

AC ELECTRICAL CHARACTERISTICS C_{load} = 50 pF, Input t_r / t_f = 3.0 ns

| Symbol | Parameter | Test Conditions | V _{CC} (V) | T _A = 25°C | | | T _A ≤ 85°C | | -55°C ≤ T _A ≤ 125°C | | Unit |
|--|---|---|---|-----------------------|-----|-----|-----------------------|-----|--------------------------------|-----|------|
| | | | | Min | Typ | Max | Min | Max | Min | Max | |
| t _{PLH} , t _{PHL} | Maximum Propagation Delay, Input X to Y | Y _A = Open (Figure 14.) | 2.0 | | 1 | 5 | | 6 | | 7 | ns |
| | | | 3.0 | | 0 | 2 | | 3 | | 4 | |
| | | | 4.5 | | 0 | 1 | | 1 | | 2 | |
| | | | 5.5 | | 0 | 1 | | 1 | | 1 | |
| t _{PLZ} , t _{PHZ} | Maximum Propagation Delay, ON/OFF Control to Analog Output | R _L = 1000 Ω (Figure 15.) | 2.0 | | 32 | 40 | | 45 | | 50 | ns |
| | | | 3.0 | | 28 | 35 | | 40 | | 45 | |
| | | | 4.5 | | 24 | 30 | | 35 | | 40 | |
| | | | 5.5 | | 20 | 25 | | 30 | | 35 | |
| t _{PZL} , t _{PZH} | Maximum Propagation Delay, ON/OFF Control to Analog Output | R _L = 1000 Ω (Figure 15.) | 2.0 | | 32 | 40 | | 45 | | 50 | ns |
| | | | 3.0 | | 28 | 35 | | 40 | | 45 | |
| | | | 4.5 | | 24 | 30 | | 35 | | 40 | |
| | | | 5.5 | | 20 | 25 | | 30 | | 35 | |
| C _{IN} | Maximum Input Capacitance | ON/OFF Control Input | 0.0 | | 3 | 10 | | 10 | | 10 | pF |
| | | Contol Input = GND | 5.0 | | 4 | 10 | | 10 | | 10 | |
| | | Analog I/O Feedthrough | | | 4 | 10 | | 10 | | 10 | |
| | | | Typical @ 25°C, V_{CC} = 5.0 V | | | | | | | | |
| C _{PD} | Power Dissipation Capacitance (Note 6) | | | | | | | | 18 | | pF |

7. C_{PD} is defined as the value of the internal equivalent capacitance which is calculated from the operating current consumption without load. Average operating current can be obtained by the equation: I_{CC(OPR)} = C_{PD} • V_{CC} • f_{in} + I_{CC}. C_{PD} is used to determine the no-load dynamic power consumption; P_D = C_{PD} • V_{CC}² • f_{in} + I_{CC} • V_{CC}.

L74VHC1GT66

ADDITIONAL APPLICATION CHARACTERISTICS (Voltages Referenced to GND Unless Noted)

| Symbol | Parameter | Test Conditions | V _{CC} | Limit 25°C | Unit |
|-----------------------|---|---|-----------------|---------------|------|
| BW | Maximum On-Channel Bandwidth or Minimum Frequency Response (Figure 10.) | f _{in} = 1 MHz Sine Wave | 3.0 | 150 | MHz |
| | | Adjust f _{in} voltage to obtain 0 dBm at V _{OS} | 4.5 | 175 | |
| | | Increase f _{in} = frequency until dB meter reads -3 dB | 5.5 | 180 | |
| | | R _L = 50 Ω, C _L = 10 pF | | | |
| ISO _{off} | Off-Channel Feedthrough Isolation (Figure 11.) | f _{in} = Sine Wave | 3.0 | -80 | dB |
| | | Adjust f _{in} voltage to obtain 0 dBm at V _{IS} | 4.5 | -80 | |
| | | f _{in} = 10 kHz, R _L = 600 Ω, C _L = 50 pF | 5.5 | -80 | |
| NOISE _{feed} | Feedthrough Noise Control to Switch (Figure 12.) | V _{in} ≤ 1 MHz Square Wave (t _r = t _f = 2ns) | 3.0 | 45 | mVPP |
| | | Adjust R _L at setup so that I _s = 0 A | 4.5 | 60 | |
| | | R _L = 600 Ω, C _L = 50 pF | 5.5 | 130 | |
| THD | Total Harmonic Distortion (Figure 13.) | f _{in} = 1 kHz, R _L = 10 k Ω, C _L = 50 pF | | | % |
| | | THD = THD Measured - THD Source | | | |
| | | V _{IS} = 3.0 V PP sine wave | 3.3 | 0.30 | |
| | | V _{IS} = 5.0 V PP sine wave | 5.5 | 0.15 | |

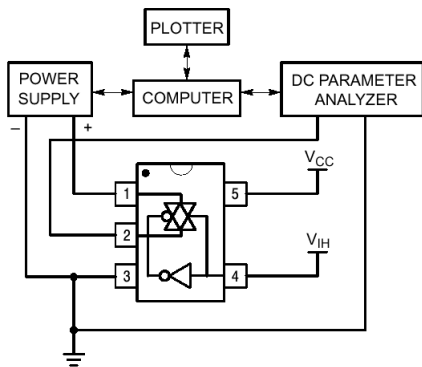

Figure 4. On Resistance Test Set-Up

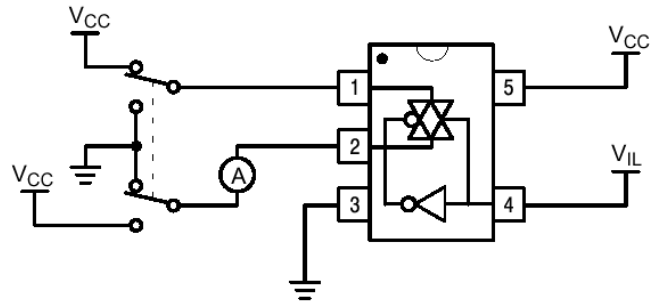

Figure 5. Maximum Off-Channel Leakage Current Test Set-Up

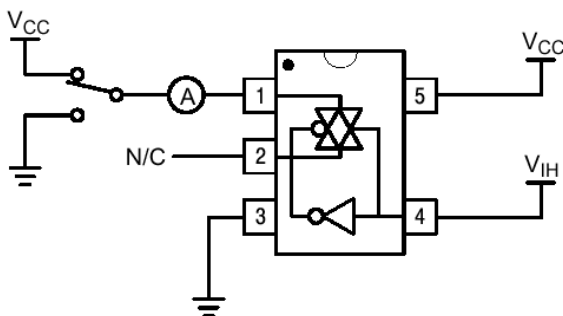

Figure 6. Maximum On-Channel Leakage Current Test Set-Up

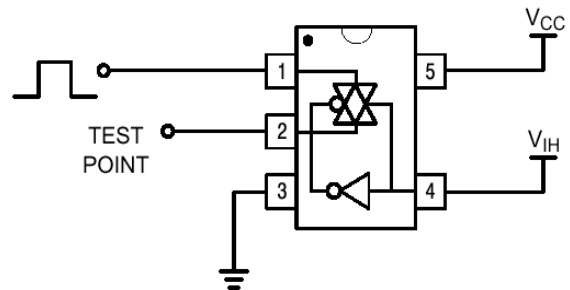

Figure 7. Propagation Delay Test Set-Up

L74VHC1GT66

Switch to Position 1 when testing t_{PLZ} and t_{PZL}
 Switch to Position 2 when testing t_{PHZ} and t_{PZH}

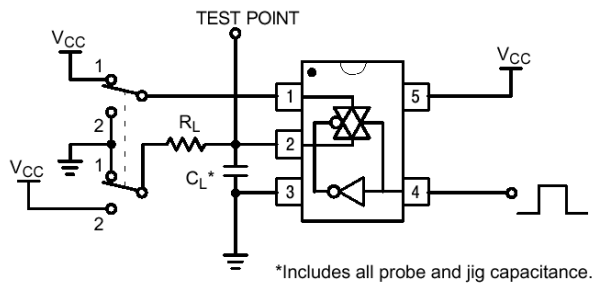

Figure 8. Propagation Delay Output Enable/Disable Test Set-Up

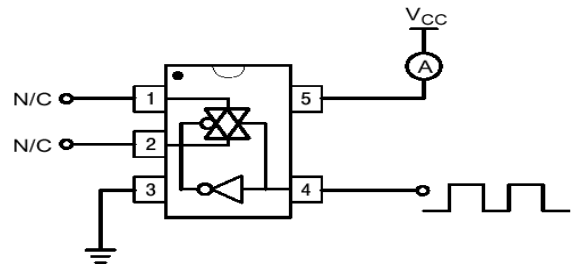

Figure 9. Power Dissipation Capacitance Test Set-Up

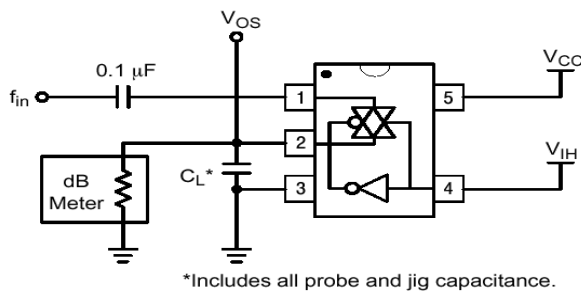

Figure 10. Maximum On-Channel Bandwidth Test Set-Up

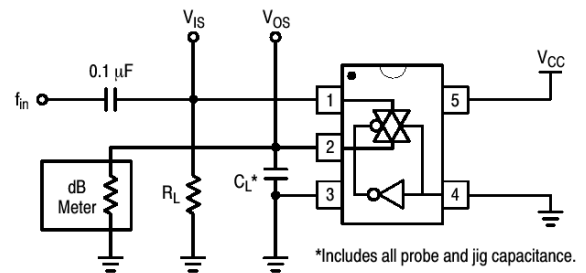

Figure 11. Off-Channel Feedthrough Isolation Test Set-Up

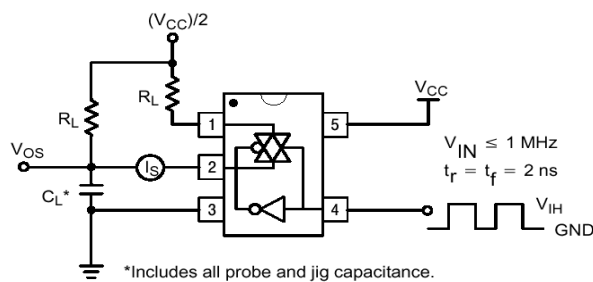

Figure 12. Feedthrough Noise, ON/OFF Control to Analog Out, Test Set-Up

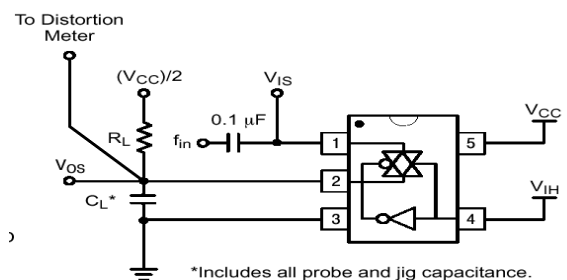

Figure 13. Total Harmonic Distortion Test Set-Up

L74VHC1GT66

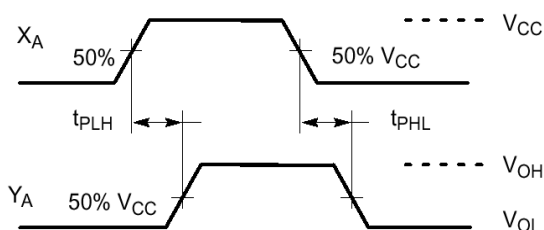

Figure 14. Propagation Delay, Analog In to Analog Out Waveforms

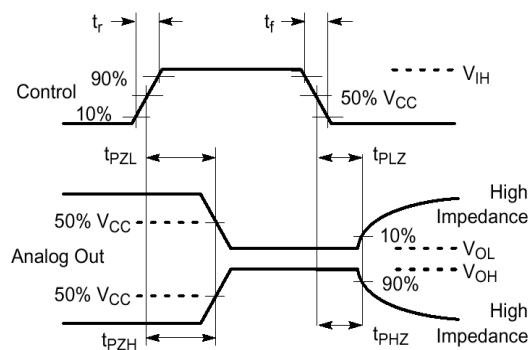

Figure 15. Propagation Delay, ON/OFF Control

DEVICE ORDERING INFORMATION

| Device Order Number | Device Nomenclature | | | | | | Package Type (Name/SOT#/Common Name) | Tape and Reel Size |
|---------------------|---------------------|-----------------------|------------|-----------------|----------------|--------------------|---|-------------------------------|
| | Circuit Indicator | Temp Range Identifier | Technology | Device Function | Package Suffix | Tape & Reel Suffix | | |
| L74VHC1GT66DFT1 | L | 74 | VHC1G | T66 | DF | T1 | SC-70/SC-88A/ SOT-353 | 178 mm (7 in) 3000 Unit |
| L74VHC1GT66DFT2 | L | 74 | VHC1G | T66 | DF | T2 | SC-70/SC-88A/ SOT-353 | 178 mm (7 in) 3000 Unit |
| L74VHC1GT66DFT4 | L | 74 | VHC1G | T66 | DF | T4 | SC-70/SC-88A/ SOT-353 | 330 mm (13 in) 10,000 Unit |
| L74VHC1GT66DTT1 | L | 74 | VHC1G | T66 | DT | T1 | SOT-23/TSOPS/ SC-59 | 178 mm (7 in) 3000 Unit |
| L74VHC1GT66DTT3 | L | 74 | VHC1G | T66 | DT | T3 | SOT-23/TSOPS/ SC-59 | 330 mm (13 in) 10,000 Unit |

L74VHC1GT50

PACKAGE DIMENSIONS SC70-5/SC-88A/SOT-353 DF SUFFIX

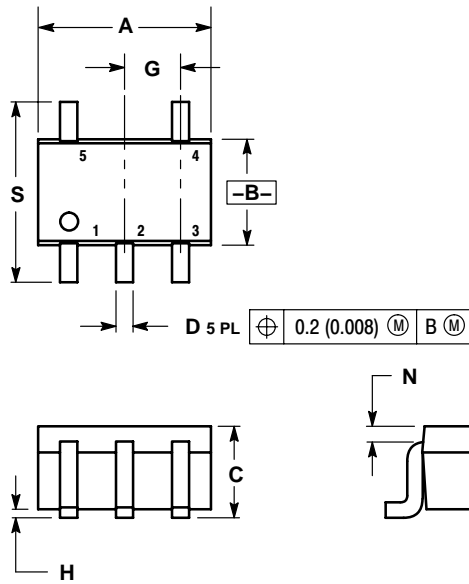

NOTES:

1. DIMENSIONING AND TOLERANCING PER ANSI Y14.5M, 1982.
2. CONTROLLING DIMENSION: INCH.
3. 419A-01 OBSOLETE. NEW STANDARD 419A-02.
4. DIMENSIONS A AND B DO NOT INCLUDE MOLD FLASH, PROTRUSIONS, OR GATE BURRS.

| DIM | INCHES | | MILLIMETERS | |
|-----|-----------|-------|-------------|------|
| | MIN | MAX | MIN | MAX |
| A | 0.071 | 0.087 | 1.80 | 2.20 |
| B | 0.045 | 0.053 | 1.15 | 1.35 |
| C | 0.031 | 0.043 | 0.80 | 1.10 |
| D | 0.004 | 0.012 | 0.10 | 0.30 |
| G | 0.026 BSC | | 0.65 BSC | |
| H | --- | 0.004 | --- | 0.10 |
| J | 0.004 | 0.010 | 0.10 | 0.25 |
| K | 0.004 | 0.012 | 0.10 | 0.30 |
| N | 0.008 REF | | 0.20 REF | |
| S | 0.079 | 0.087 | 2.00 | 2.20 |

SOLDERING FOOTPRINT*

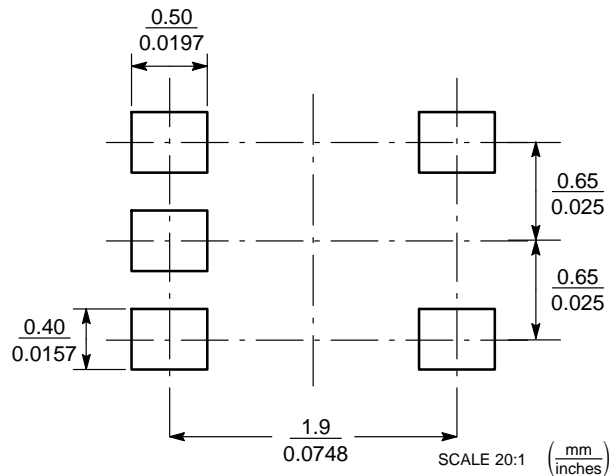

L74VHC1GT50

PACKAGE DIMENSIONS

SOT23-5/TSOP-5/SC59-5
DT SUFFIX

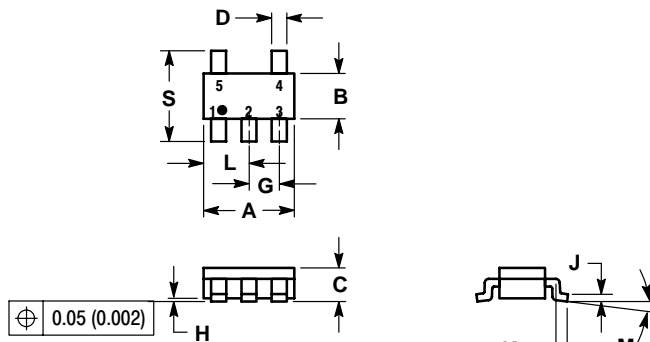

NOTES:

1. DIMENSIONING AND TOLERANCING PER ANSI Y14.5M, 1982.
2. CONTROLLING DIMENSION: MILLIMETER.
3. MAXIMUM LEAD THICKNESS INCLUDES LEAD FINISH THICKNESS. MINIMUM LEAD THICKNESS IS THE MINIMUM THICKNESS OF BASE MATERIAL.
4. A AND B DIMENSIONS DO NOT INCLUDE MOLD FLASH, PROTRUSIONS, OR GATE BURRS.

| DIM | MILLIMETERS | | INCHES | |
|-----|-------------|-------|--------|--------|
| | MIN | MAX | MIN | MAX |
| A | 2.90 | 3.10 | 0.1142 | 0.1220 |
| B | 1.30 | 1.70 | 0.0512 | 0.0669 |
| C | 0.90 | 1.10 | 0.0354 | 0.0433 |
| D | 0.25 | 0.50 | 0.0098 | 0.0197 |
| G | 0.85 | 1.05 | 0.0335 | 0.0413 |
| H | 0.013 | 0.100 | 0.0005 | 0.0040 |
| J | 0.10 | 0.26 | 0.0040 | 0.0102 |
| K | 0.20 | 0.60 | 0.0079 | 0.0236 |
| L | 1.25 | 1.55 | 0.0493 | 0.0610 |
| M | 0 | 10 | 0 | 10 |
| S | 2.50 | 3.00 | 0.0985 | 0.1181 |

SOLDERING FOOTPRINT*

