

1. Feature&Dimension

1.1. DO-34:

单
位:(mm)

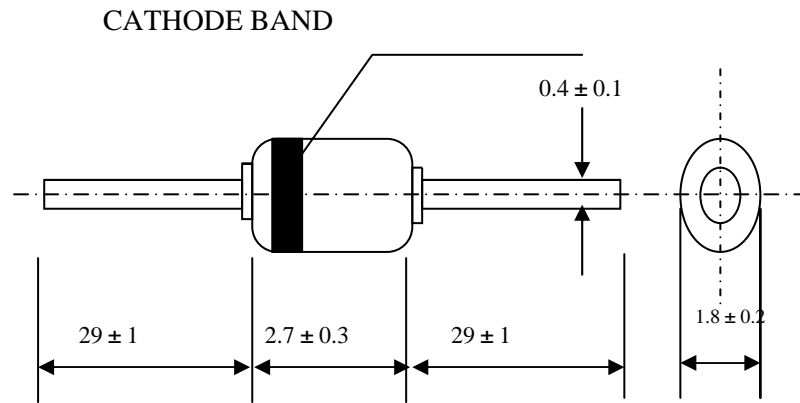

1.2 DO-35

单
位:(mm)

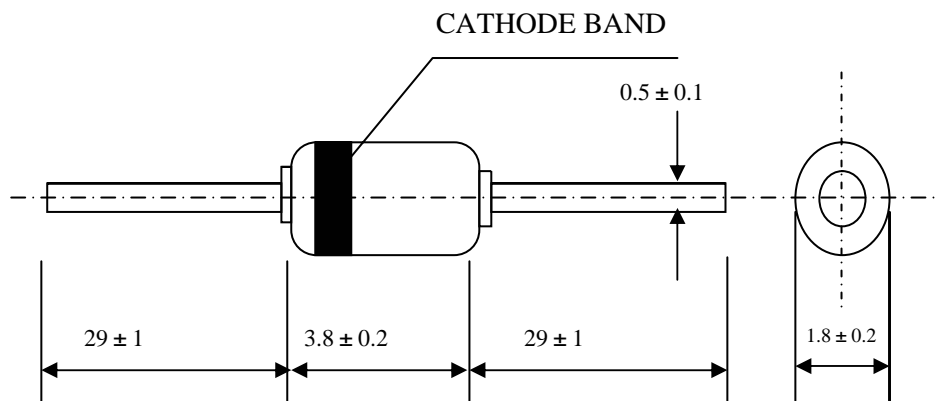

BI-DIRECTIONAL TRIGGER DIODES

2. DO-35 玻壳封装双向触发二极管

DO-35 GLASS-SEALED BI-DIRECTIONAL TRIGGER DIODES

符号 Symbol	参数 Parameter	测试条件 Test Condition	型号 Type	Min	Typ	Max	Unit	外型尺寸 Package (单位: mm)
V_{BO}	击穿电压 Breakdown Voltage	见图 1 See Fig 1	DB-3 DB-4 DB-6	28 35 56	32 40 60	36 45 70	V	 <p style="text-align: center;">DO-35 (mm)</p>
$ +V_{BO} - -V_{BO} $	击穿电压对称性 Breakover Voltage Symmetry	见图 1 See Fig 1	DB-3 DB-4 DB-6			3 3 4	V	
$ \pm \Delta V $	动态回弹电压 Dynamic Breakback Voltage	$\Delta I = I_{BO} \text{ to } I_F = 10\text{mA}$ 见图 1 See Fig 1	DB-3 DB-4 DB-6	5 5 10			V	
V_O	输出电压 Output Voltage	见图 2 See Fig 2		5			V	
I_{BO}	击穿电流 Breakdown Current					100	μA	
t_r	上升时间 Rise Time	见图 3 See Fig 3			1.5		μs	
I_B	漏电流 Leakage Current	$V_m = 0.5V_{BO}(\text{Max})$ 见图 1 See Fig 1				10	μA	

极限参数

LIMITING VALUES

符号 Symbol	参数 Parameter	Value	Unit
P_C	功耗 Power Dissipation	$t_a = 50^\circ\text{C}$ 150	mW
I_{Fmax}	峰值脉冲电流 Peak Pulse Current	$t_p = 10\mu\text{s}$ 120pps $T_a \leq 40^\circ\text{C}$	A
T_r T_J	贮存与工作结温范围 Storage and Operating Junction Temperature Range	40 to 125 40 to 110	$^\circ\text{C}$

3. DO-35 玻壳封装双向触发二极管特性曲线

DO-35 GLASS-SEALED BI-DIRECTIONAL TRIGGER DIODE

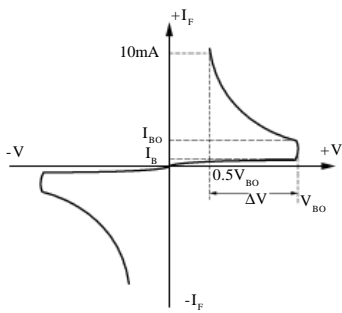

FIG-1 I - V 特性曲线
Current - voltage characteristics

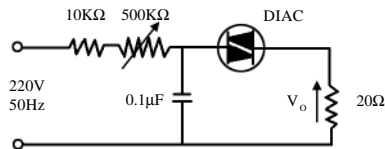

FIG-2 输出电压测试电路
Test circuit for output voltage

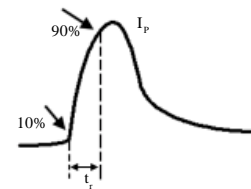

FIG-3 测试电路见图2, 调整R, $I_P=0.5A$
Test circuit see diagram 2. Adjust R for $I=0.5A$

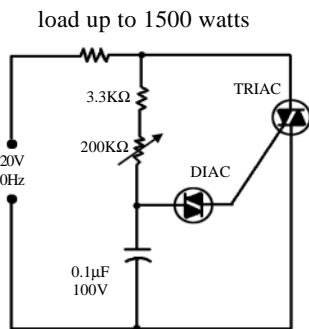

FIG-4 典型 DIAC-TRIAC 全波相控电路
Typical DIAC-TRIAC full-wave Phase control

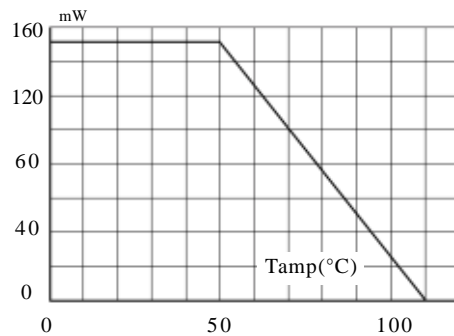

FIG-5 功耗环境温度关系曲线 (最大值)
Power dissipation versus ambient temperature(maximum values)

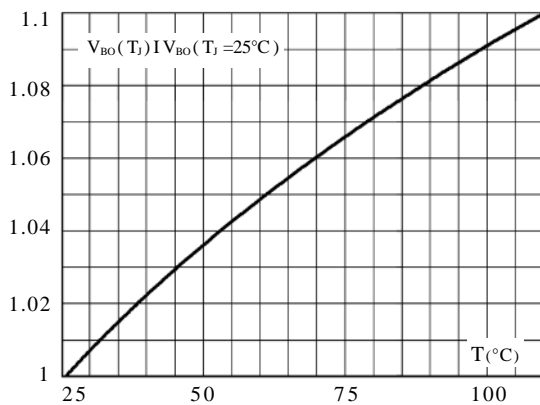

FIG-6 V_{BO} 的相对变化与结温关系曲线 (典型值)
Relative variation of V_{BO} versus junction temperature (typical values)

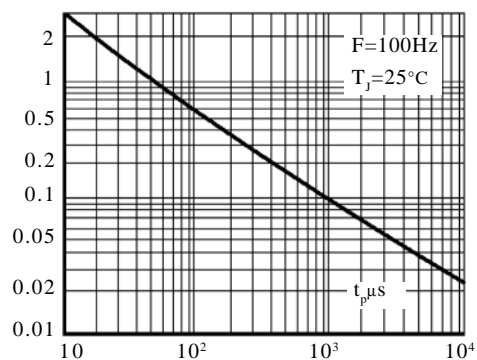

FIG-7 峰值脉冲电流与脉冲宽度关系曲线 (最大值)
Peak pulse Current versus pulse duration (maximum values)

4.MainMaterialList

4.1

NO	Material	Type	Spec.	Qty/K	Supplier
1	Chip	Zener Diode	0.35×0.35	1K	ROHM、THINKO
2	Glass	LG-16	DO-34	1K	CHINA
3	Leadwire	STP100	DO-34	2K	CHINA
4	Cu/Sn	HLSn	Sn/Cu : 99.3/0.7	0.07Kg	CHINA
5	Tape	COMR	6×0.17mm	5.3M/K	CHINA
6	Ink	UV	Black	0.08g/K	JAPAN

4.2

NO	Material	Type	Spec.	Qty/K	Supplier
1	Chip	Zener Diode	0.35×0.35	1K	ROHM、THINKO
2	Glass	LG-16	DO-35	1K	CHINA
3	Leadwire	STP100	DO-35	2K	CHINA
4	Cu/Sn	HLSn	Sn/Cu : 99.3/0.7	0.07Kg	CHINA
5	Tape	COMR	6×0.17mm	5.3M/K	CHINA
6	Ink	UV	Black	0.08g/K	JAPAN

4.3

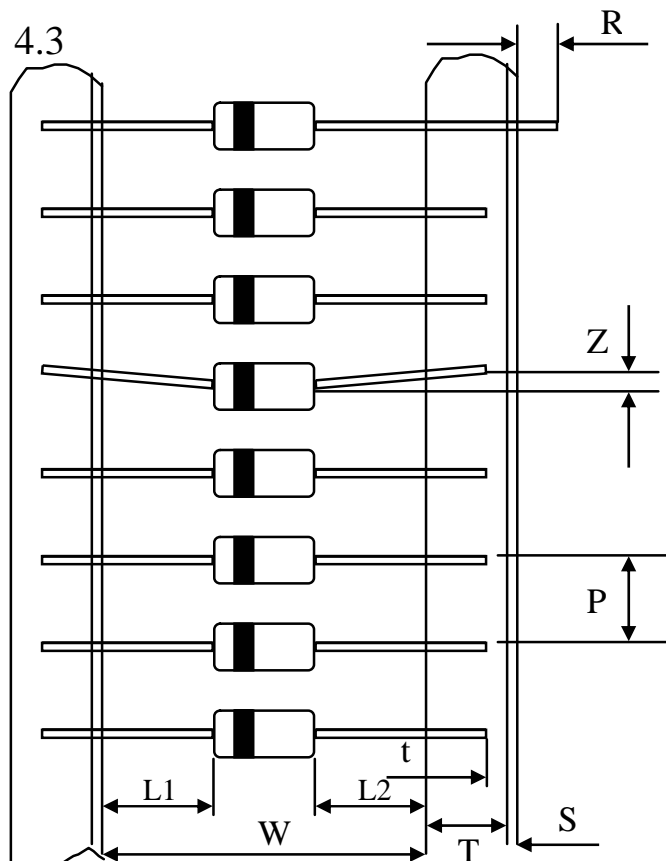

尺寸 代号	编带规格	
	26编带	52编带
W	26 + 1	52 ± 0.5
P	5 ± 0.5	5 ± 0.5
L ₁ -L ₂	1.0	1.0
T	6 ± 0.5	6 ± 0.5
Z	<0.5	<1.0
R	0	0
t	>3.2	>3.2
S	<0.5	<0.5

5. Marking Identification

5.1 D0-34

单位：(mm)

例：

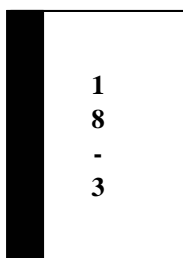

5.2 D0-35

单位：(mm)

例：

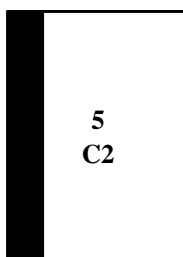

6. Packing

6.1 Taping / Box(T52)

6.1.1 Taping Quantity: 5000 ± 10pcs/each

6.1.2 Tape Inner Box: 5000pcs/each

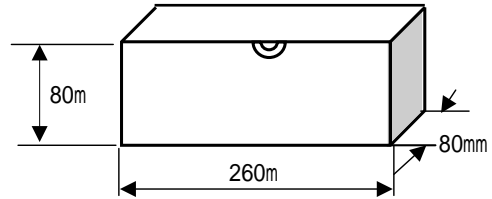

6.2 Taping / Box(T26)

6.2.1 Taping Quantity: 5000 ± 10pcs/each

6.2.2 Tape Inner Box: 5000pcs/each

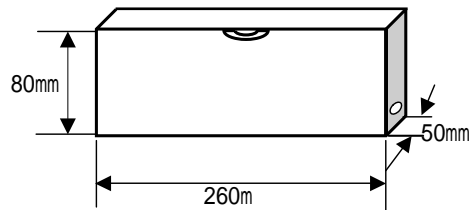

6.3 Outer Box 50000pcs/each

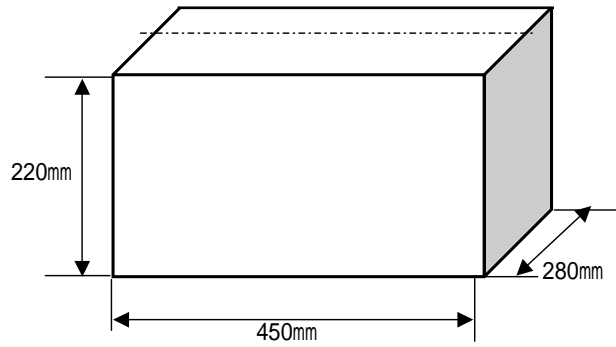

6.4 Bulk

6.4.1 500pcs/bag

6.4.2 10000pcs /each

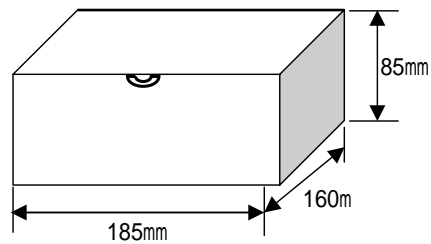

6.4.3 Outer Box 120000pcs/each

